



INNOVATION WORKING FOR YOU

**AOSCC24SP
Aera Seeder
OPERATOR & PARTS MANUAL**



REIST Industries Inc.
100 Union Street
Elmira, Ontario, Canada
N3B 3L7

Phone: 519-669-1501
Fax: 519-669-3021
Toll Free: 1-877-467-3478
www.reistindustries.com

Effective Serial Number W3529

Contents	
INTRODUCTION.....	4
PRODUCT SPECIFICATIONS.....	5
GENERAL SAFETY	5
CONTROLS	7
OPERATION.....	8
CALIBRATION	8
CALIBRATION	9
ADJUSTMENTS.....	9
ADJUSTMENTS.....	10
MAINTENANCE	10
STORAGE.....	11
HANDLE & CONTROL BRACKET ASSEMBLY.....	12
TRANSMISSION & CONTROL PARTS	13
MOTOR ASSEMBLY PARTS.....	14
TRANSMISSION TO AGITATOR DRIVE CONNECTION.....	15
TRANSMISSION ROLLERCHAIN ASSEMBLY DETAIL.....	16
SEED GATE ASSEMBLY PARTS	17
SEED RATE CONTROL ASSEMBLY PARTS	18
LID & LATCH ASSEMBLY PARTS	19
SPIKED ROLL TO REAR SPIKED ROLL DRIVE CONNECTION	20
AGITATOR TO FRONT SPIKED ROLL DRIVE CONNECTION	21
REAR SPIKED ROLL & SCRAPER ASSEMBLY	22
FRONT CONE SCRAPER & CALIBRATION TRAY ASSEMBLY	23
BRUSH ASSEMBLY	24
PARTS – DRIVE ROLL & BROOM.....	25
PARTS – REAR SPIKE DRIVE ROLL.....	26
OPTIONAL 2” WIDE x 8” DIA GAUGE WHEEL KIT.....	27
OPTIONAL 2” WIDE GAUGE WHEEL KIT – DETAIL A.....	28
OPTIONAL 4” WIDE x 8” DIA GAUGE WHEEL KIT.....	29
OPTIONAL WEIGHT BRACKET KIT	30
WARRANTY INFORMATION.....	31

Record your product information for future reference:

Model Number: _____

Serial Number: _____

In Service Date: _____

Sold By: _____

INTRODUCTION

CONGRATULATIONS!!

Thank you for choosing the **Reist Self Propelled AeraSeeder**. We feel confident that this equipment will meet your expectations in workmanship, reliability and performance.

This manual is to assist you with the safe operation of the AeraSeeder.

The Reist AeraSeeder is a versatile piece of equipment to facilitate various primary and over seeding requirements. It provides simple, yet accurate initial and overseeding in those "hard to get at" places. At only 33" wide, with a seeding width of 24", this mighty little machine will quickly overseed your golf greens and it can also fit through a backyard gate. The multi-spiked roller produces approximately 800 perforations per square yard, effectively saturating the top surface with a network of holes. This network, combined with our stainless steel seed apertures, brush, and smooth packing roller system, offer you the highest percentage of grass seed germination.

For primary seeding, the spike roll breaks up clumps and packs the ground. The seed is then dropped by the seeder and the brush lightly covers the seed. The smooth roll presses the soil to keep the moisture in the ground.

For over seeding the spiked roll pokes small holes into the ground. The seed that falls onto the grass is brushed into the holes created by the spiked roller. The smooth roll presses down to cover the seed and keep the moisture in.

Replacement copies of this manual are available for downloading at:
www.reistindustries.com

Innovation Working For You

REIST Industries Inc.

100 Union Street
Elmira, Ontario, Canada
N3B 3L7

Phone: 519-669-1501
Fax: 519-669-3021
Toll Free: 1-877-467-3478

The illustrations and information contained within this manual were current at the time of publication. Under our policy of continuous improvement, we reserve the right to change specifications and designs without prior notice. The illustrations do not necessarily show the standard version of product offered by REIST Industries.

PRODUCT SPECIFICATIONS

- Multi-spiked rollers delivering approximately 1700 perforations per square yard
- Powered by a 5.5 horsepower Honda gasoline engine. See Honda manual (included) for operation instructions
- Eaton hydrostatic transmission
- Power is delivered via a series of sprockets, shaft and chains
- Less than 33" standard overall width x 60" length x 37" height
- Seeding width of 24"
- 1.25 bushels seed bin capacity
- Seed calibration tray
- Standard rear smooth packing roller or optional additional rear spiked roller (increases perforations to approximately 1700 per square yard)
- Cam-adjusted seed gate
- User-friendly controls
- Optional - Gauge wheel kit, with quick release wheels
 - 2" wide x 8" diameter solid rubber wheels (Overall width increases to 37")
 - 4" wide x 8" diameter solid rubber wheels (Overall width increases to 41")
- Optional - Weight bracket for up to 6 @ 45lb weights

GENERAL SAFETY

Careful operation is the best assurance against accidents. It is the owner's responsibility to make sure that all operators read and understand this manual and follow the recommendations, cautions and warnings before operating the equipment.

Familiarize yourself with all controls and know how to quickly stop the equipment and all rotating parts in the case of an emergency.

Never let an untrained person or a child operate equipment.



WARNING!

DO NOT MODIFY THE REIST EQUIPMENT

Modifications may weaken the integrity of the equipment and may impair the operation, safety, and performance of the product. When making repairs, only qualified technicians using the manufacturer's genuine parts, following authorized instructions, shall attempt the repair. Never remove guarding or other safety device. Any modifications must be sanctioned in writing by an authorized representative of the manufacturer.



WARNING!

MAINTAIN AND REPAIR EQUIPMENT SAFELY

- Do not wear loose clothing, or any accessories that can catch in moving parts
- If you have long hair, cover or secure it so that it does not become entangled in the equipment
- Work on a level surface in a well-lit area.
- Always secure and support it to prevent unintentional movement
- Use the correct tool for the job at hand. Make sure they are in good condition for the task required
- Wear the protective equipment specified by the tool manufacturer
- Use care when working on hydraulic systems and understand how to check for and release trapped hydraulic pressure



WARNING!

READ OPERATOR'S MANUAL BEFORE OPERATING

Do not operate equipment until you are completely trained by a qualified operator in how to use the controls, understand the machine's capabilities, dimensions, and all safety requirements. Refer to your operator's manual for these instructions.

- Do not operate an engine in confined or non-ventilated area
- Do not perform adjustments or repairs with the engine running
- Do not operate on excessive inclines or side slopes– be careful when turning on slopes as a rollover condition may exist
- Keep bystanders away from the machine when in operation
- Be aware of pedestrians
- Know how to quickly stop the equipment in the case of an emergency

CONTROLS

1. Opens and closes grass seed flow
2. Starts, stops, and reverses Aera Seeder. This is variable speed which means the more the lever gets squeezed the faster the Aera Seeder moves.
3. Kill switch lever must be held to start engine.
4. Manual holder tube. Keep manual here for quick reference.
5. Hydraulic oil for Transmission. Check oil level daily.
6. Honda GX360 engine on/off switch. For more information see engine manual.
7. Turn cam to adjust amount of seed required. The higher the number, the more seed is applied.
8. Controls depth of brush. As bristles wear hairpin is moved to a higher hole.

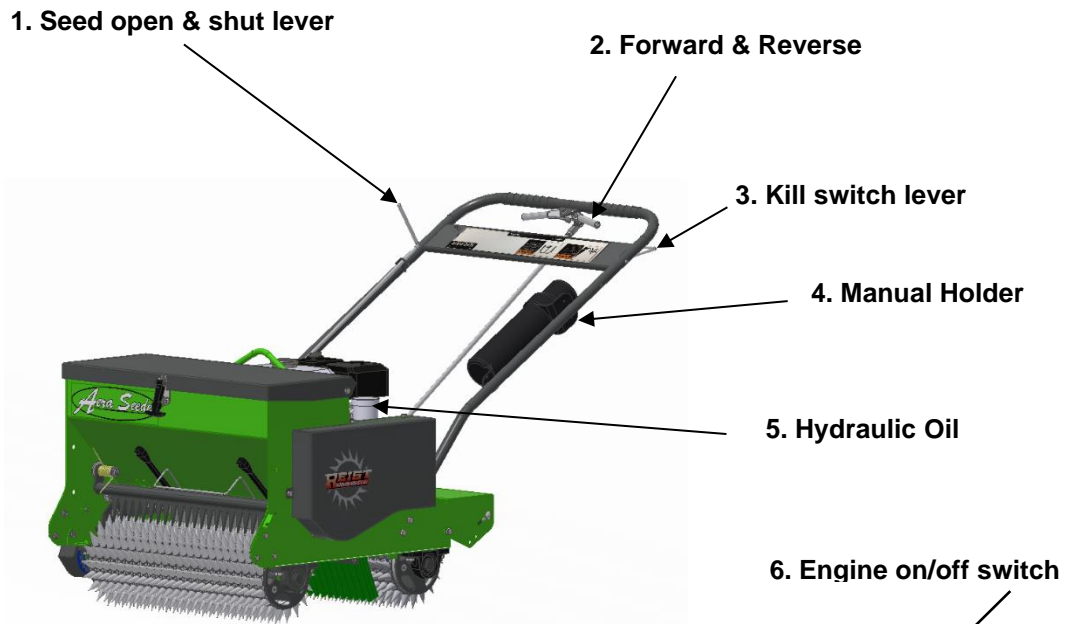

Fig. 1

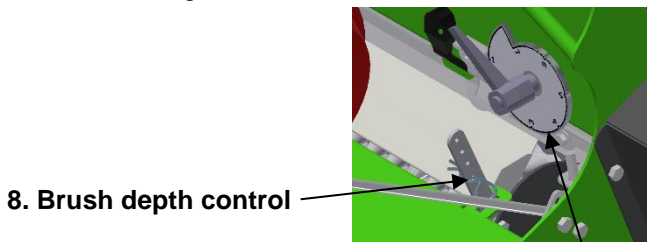

Fig. 2

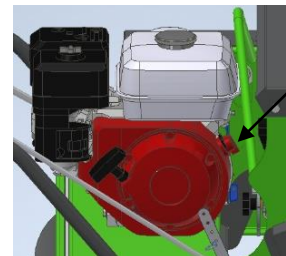

Fig. 3

OPERATION

1. Before starting check oil in transmission and engine.
2. Check gas
3. Close seed flow lever.
4. Pour grass seed into bin. Make sure it is clean seed with no dirt lumps or foreign objects.
5. To start engine, the engine switch must be in ON position.
6. Kill switch lever needs to be held to start engine.
7. When starting cold engine, put on choke and pull cord until engine fires.
8. Turn off choke.
9. When engine is warm choke is normally not necessary.
10. To move, squeeze Forward and Reverse lever. The more it is squeezed the faster the Aera Seeder will travel.
11. To start seeding, squeeze the Forward lever, and open the seed flow lever.
12. Turning a sharp corner can be done by either lifting or pushing down on the handle.
13. If seeding soft turf or depth needs to be controlled see section on "Adjustments".

CALIBRATION

It is easy to calibrate the seed rate and can be done in a reasonably short amount of time. All you need is a measuring tape, weigh scale, and container. Then follow the steps below.

1. Measure a distance of **166 ft**
2. Pour several pounds of seed into seed box
3. Insert calibration tray on mounting hooks below seed outlet at the bottom of the seeder.
4. Set Seed Rate Indicator to the approximate seed rate according to chart on next page.
5. Open seed slider and start AeraSeeder travelling at the same speed as you will be when you are seeding (approx 3 MPH/5km). Close seed slide when you pass the end mark then turn around and come back to the starting point. (If the tray is filled before getting to the end mark, stop and empty calibration tray into a container then continue. Depending on the seed rate you might have to empty the tray a couple of times.)
6. Weigh the collected seed and multiply the total by 3. The product is the pounds per thousand square feet.

Example: if 2.5 pounds collected in tray

$$3 \times 2.5 = 7.5 \text{ lbs}/1000 \text{ ft}^2$$

CALIBRATION

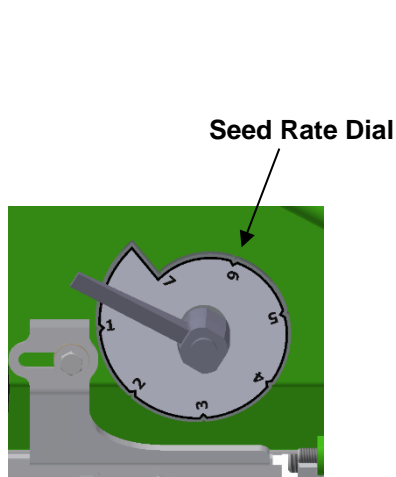

Fig. 4

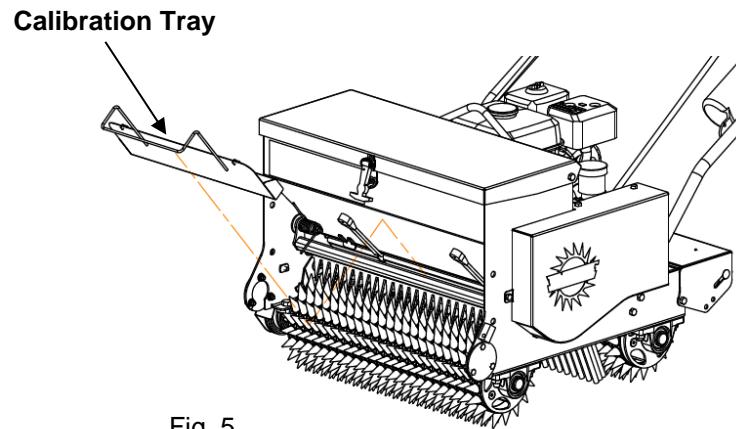

Fig. 5

ADJUSTMENTS

1. Tightening Drive Chains

There are three drive chains on the AOSCS24SP that need to be checked periodically. Two are tightened with idle sprockets **Fig. 6 & 7**. The chain that drives the rear roller is tightened by loosening the roller bearing. Then with a pry bar as seen in **Fig. 6** pry the bearing back until there is no slack in chain.

2. Speed Adjustment

The forward and reverse speed is adjusted by two bolts. The front bolt **Fig. 7** adjusts the reverse speed and the rear bolt towards the handle adjusts the forward speed. Turning clockwise increases speed and counter clockwise decreases speed.

3. Neutral Adjustment

If the Aera Seeder creeps when forward & reverse lever is released, adjustment needs to be made. The nuts compressing the springs in **fig.8** need to be tightened or loosened. However much one nut is tightened the other nut should be loosened.

ADJUSTMENTS

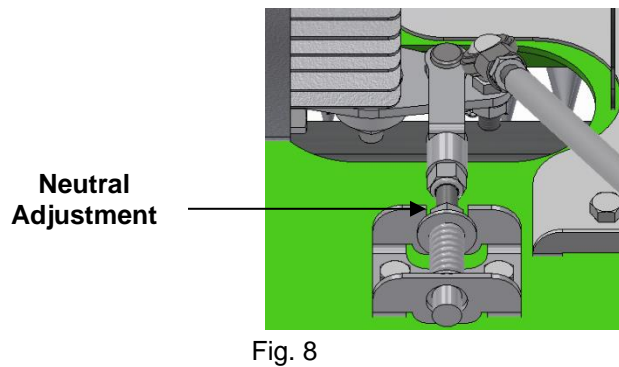
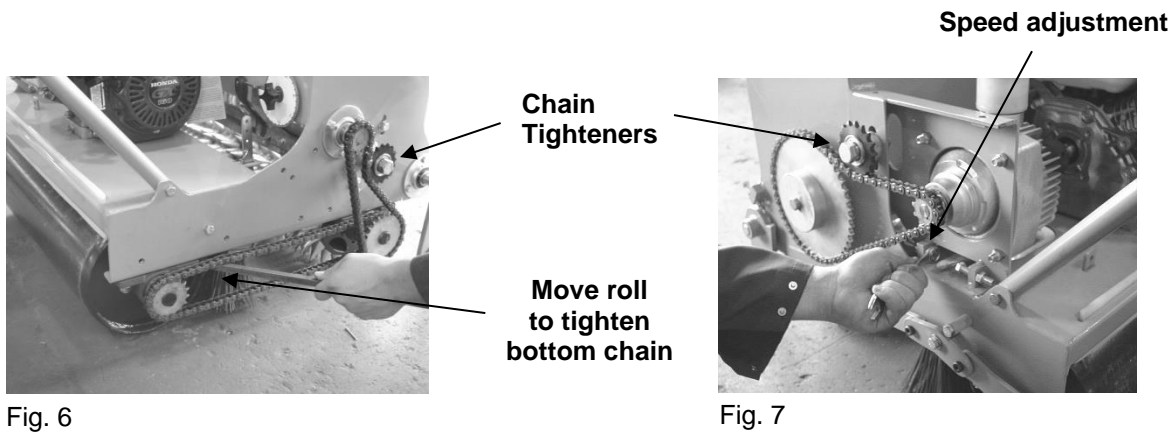

MAINTENANCE

Refer to the General Safety Precautions, in previous pages of this manual before performing any maintenance.

1. At the beginning of each season, ensure that all fasteners are properly torqued, all safety guards are in place and that operator's manual is reviewed and understood
2. Daily, check that oil is at level mark on transmission reservoir (approx. 1/8" from bottom). Check when cool. When hot the level in reservoir will rise.
3. Daily, check engine oil.
4. Keep roller chains snug. Adjustment instructions are on preceding page.

STORAGE

1. Clean out seed bin.
2. Clean before putting into storage. May be washed with pressure washer.
3. Touch-up paint as needed.
4. Oil seeder chains.
5. Store in dry, ventilated area.

HANDLE & CONTROL BRACKET ASSEMBLY

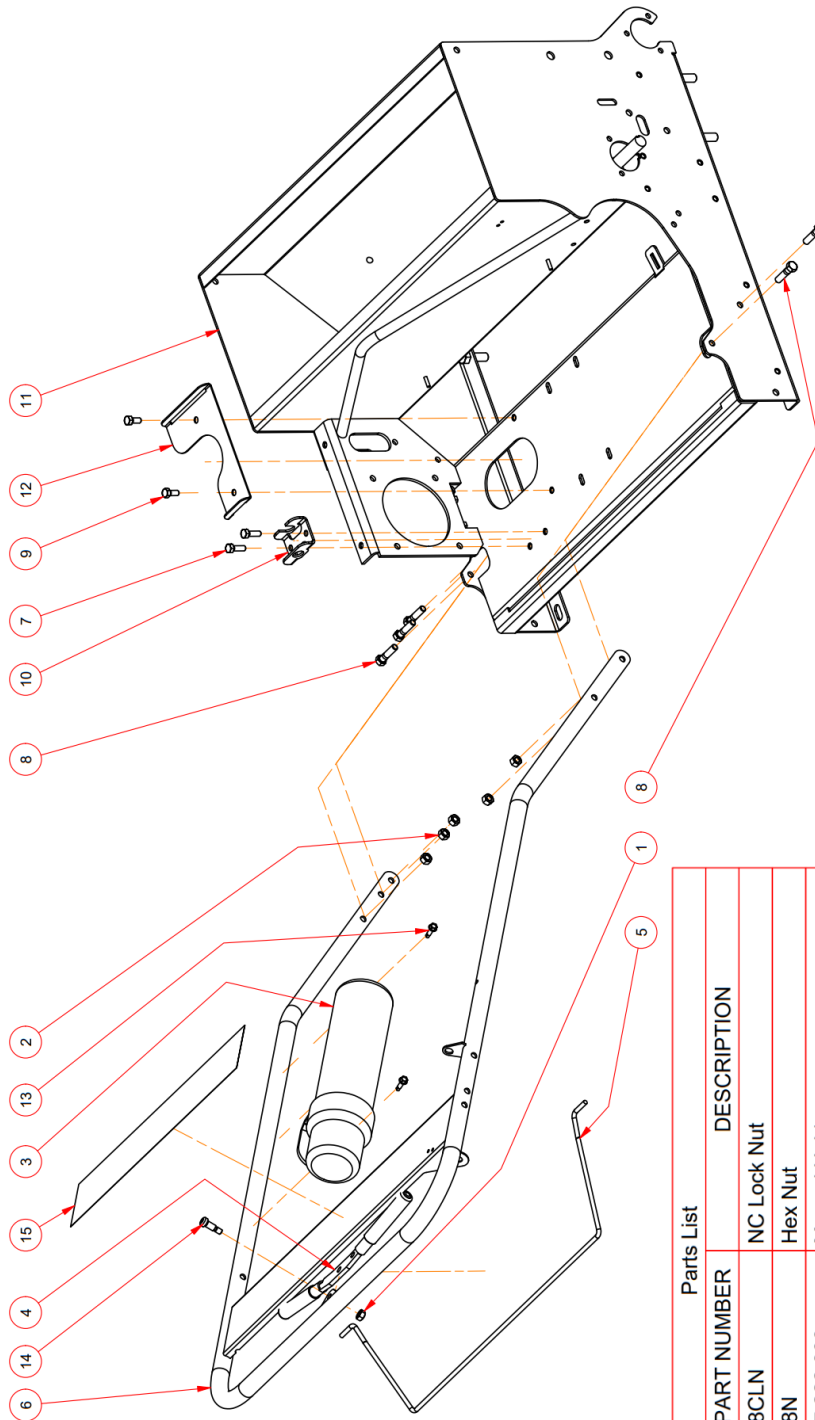

Parts List

ITEM	QTY	PART NUMBER	DESCRIPTION
1	1	38CLN	NC Lock Nut
2	5	38N	Hex Nut
3	1	67.222.000	Manual Holder
4	1	5111-AB	Finger Lever
5	1	5126	Kill Lever
6	1	102459	Handle AOS24SP
7	2	5161	Hex Bolt
8	5	38112	Hex Bolt
9	2	51634	Hex Bolt
10	1	118090	Spring Mount
11	1	118648	Hopper Weldment AOS24SP
12	1	118806	Shield Lock Bracket
13	2	2167121	Self Drilling 14x1 Metal Screw
14	1	HX-3811SB	Hex Head Shoulder Bolt
15	1	WD110	AOSCS24SPEU Control Panel Decal

TRANSMISSION & CONTROL PARTS

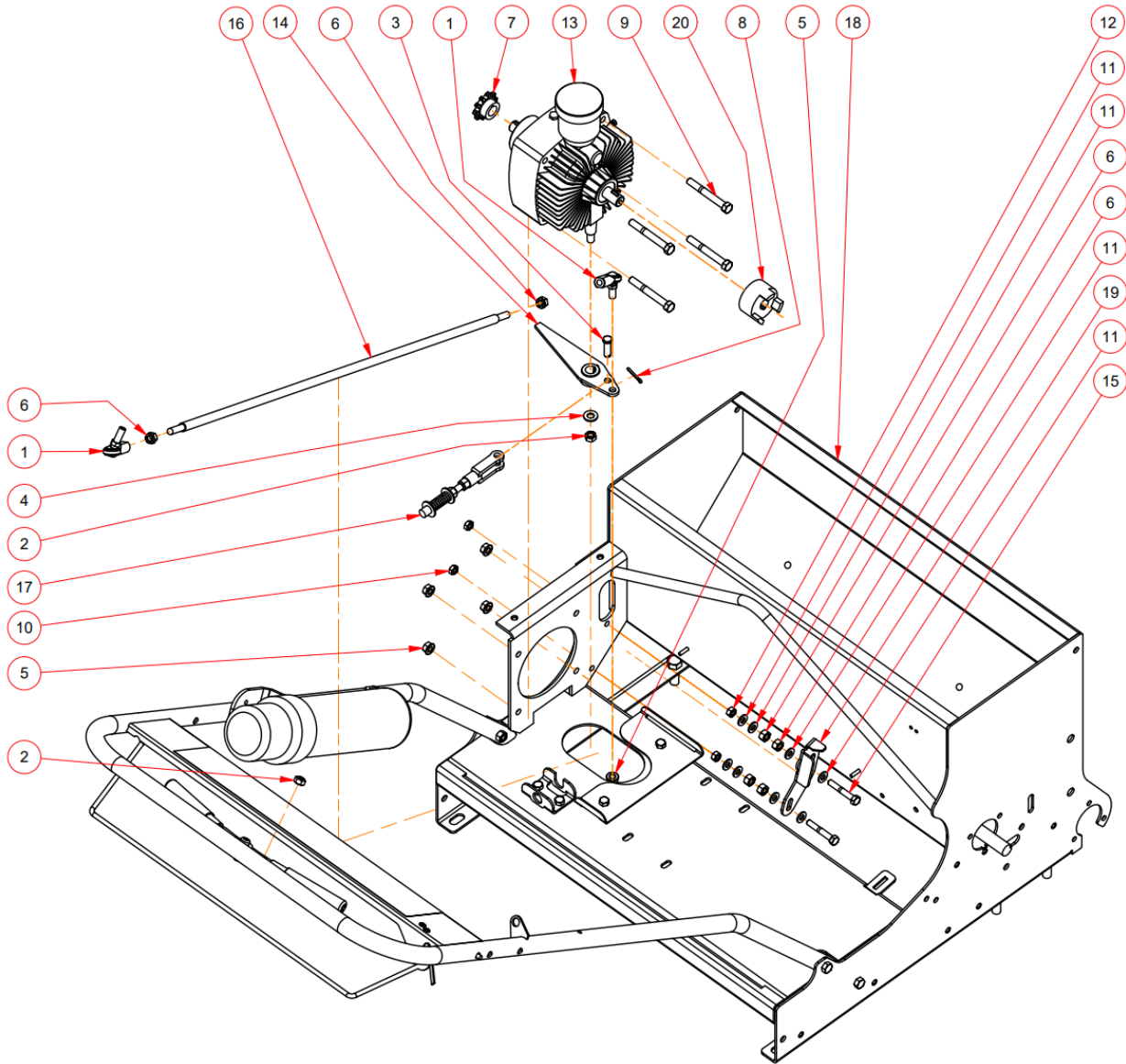

Parts List				Parts List			
ITEM	QTY	PART NUMBER	DESCRIPTION	ITEM	QTY	PART NUMBER	DESCRIPTION
1	2	09CW-6S 38	3/8" M-F Rod End	11	8	516FL	BP Flat Washer
2	2	38CLN	NC Lock Nut	12	2	516N	Hex Nut
3	1	38CP	3/8x1-1/4 Pin	13	1	700-004	Hydraulic Unit
4	1	38FL	BP Flat Washer	14	1	5114	Transmission Lever
5	5	38FSLN	Flange Nut	15	2	5162	Hex Bolt
6	6	38N	Hex Nut	16	1	118080	Drive Control Rod
7	1	40B10X17MM	Roller Chain Sprocket - 40B10X17MM	17	1	118089	Neutral Position
8	1	181CP	Cotter Pin	18	1	118648	Hopper Weldment AOS24SP
9	4	383	Hex Bolt	19	1	130526-AA	Release Latch
10	2	516CLN	NC Lock Nut	20	1	L095X17MM	Lovejoy-Coupling

MOTOR ASSEMBLY PARTS

Parts List			
ITEM	QTY	PART NUMBER	DESCRIPTION
1	4	516FSLN	Flange Nut
2	2	1434	Hex Bolt
3	1	118648	Hopper Weldment AOS24SP
4	1	118781	Fan
5	1	118803	Fan Shield
6	2	119279	Honda GX160 Bolt Plate Weldment
7	1	GX160UTQH6	5.5 Honda GX160 Engine
8	1	L095-0.75-RM	Lovejoy-Coupling - Reist Modified
9	1	L095i	LoveJoy Spider

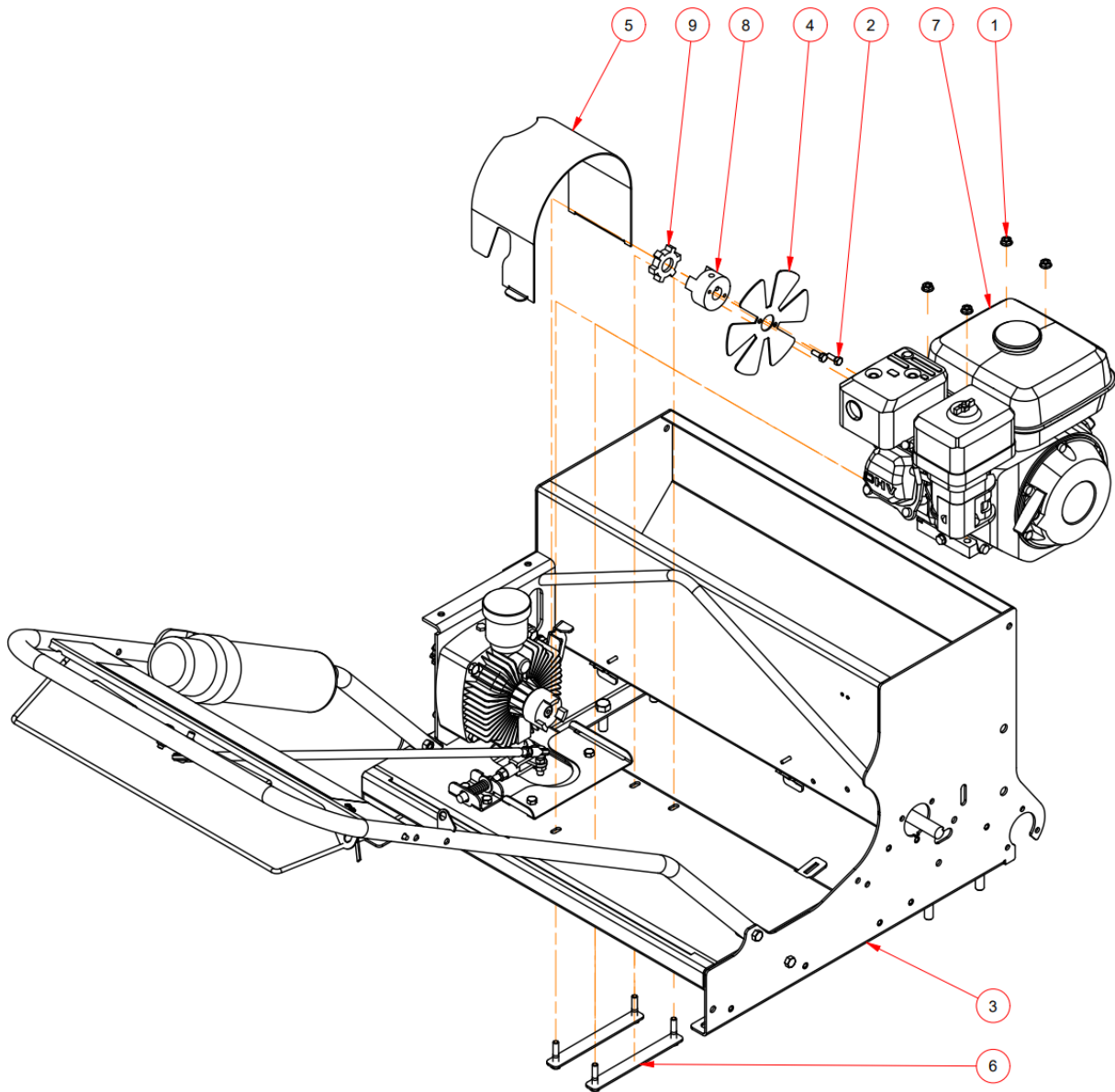

TRANSMISSION TO AGITATOR DRIVE CONNECTION

Parts List			
ITEM	QTY	PART NUMBER	DESCRIPTION
1	13	38N	Hex Nut
2	1	40B10X17MM	Roller Chain Sprocket - 40B10X17MM
3	1	40B48X34	Roller Chain Sprocket - 40B48X3/4
4	3	40RC	Roller Chain
5	3	58F	Flat Washer
6	1	58N	Hex Nut
7	17	516FSLN	Flange Nut
8	1	5112	Agitator Drive Chain Shield
9	1	5115	Idler Bushing Left
10	1	5136	Seed Slide Lever
11	25	51634	Hex Bolt
12	1	58212	Hex Bolt
13	1	100567	Slide Lever Bracket
14	1	100571	Slide Lever Mount Bracket
15	1	125695	AOS Disc Agitator 24
16	1	118648	Hopper Weldment AOS24SP
17	2	20401708	*Varies*
18	2	FT-9	Fully Threaded Bolt 1-1/2
19	4	PF204	brg flange
20	2	UC204012	Bearing Insert

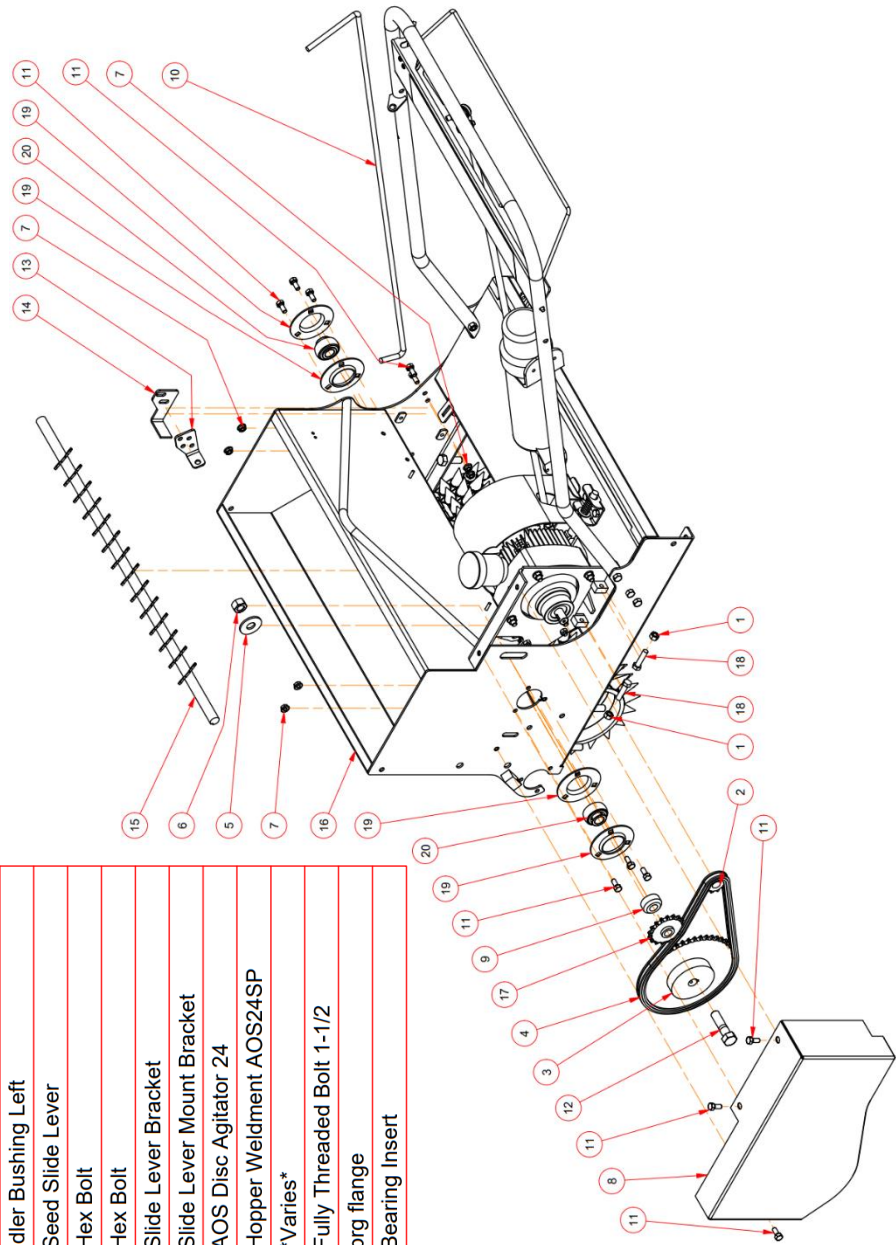

TRANSMISSION ROLLERCHAIN ASSEMBLY DETAIL

Parts List			
ITEM	QTY	PART NUMBER	DESCRIPTION
1	1	40B10X17MM	Roller Chain Sprocket - 40B10X17MM
2	1	40B48X34	Roller Chain Sprocket - 40B48X34
3	1	40RC	Roller Chain
4	1	58N	Hex Nut
5	1	5112	Agitator Drive Chain Shield
6	1	5115	Idler Bushing Left
7	3	51634	Hex Bolt
8	1	58212	Hex Bolt
9	1	20401708	Tensioner Sprocket

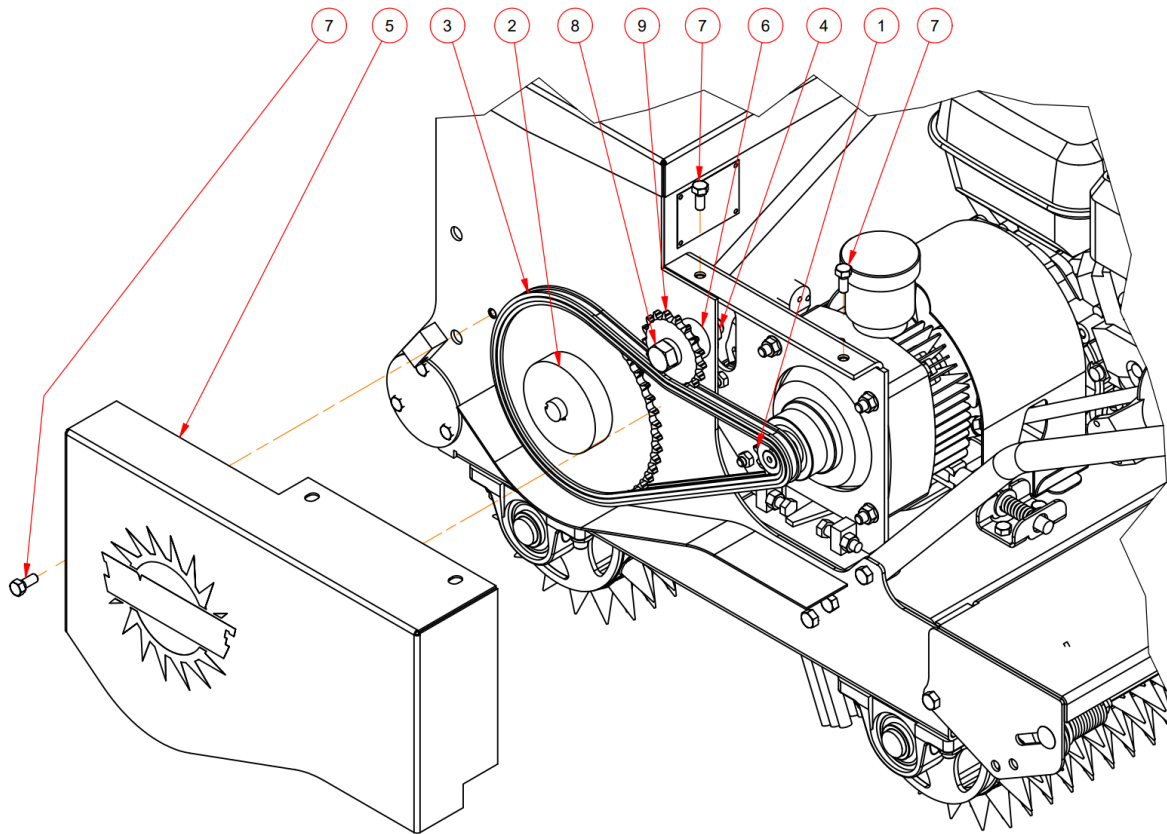

SEED GATE ASSEMBLY PARTS

Parts List			
ITEM	QTY	PART NUMBER	DESCRIPTION
1	1	14FLN	NF Lock Nut
2	4	14FW	Flat Washer
3	8	680-816	Bellville Washer 20th
4	1	14112NF	BP NF Hex Bolt
5	1	100572	SS Slider Assembly AOS24SP
6	1	118648	Hopper Weldment AOS24SP
7	1	508524	Seed Insert
8	2	SH-9	Tarp Strap
9	2	UH-11	Fiber Washer

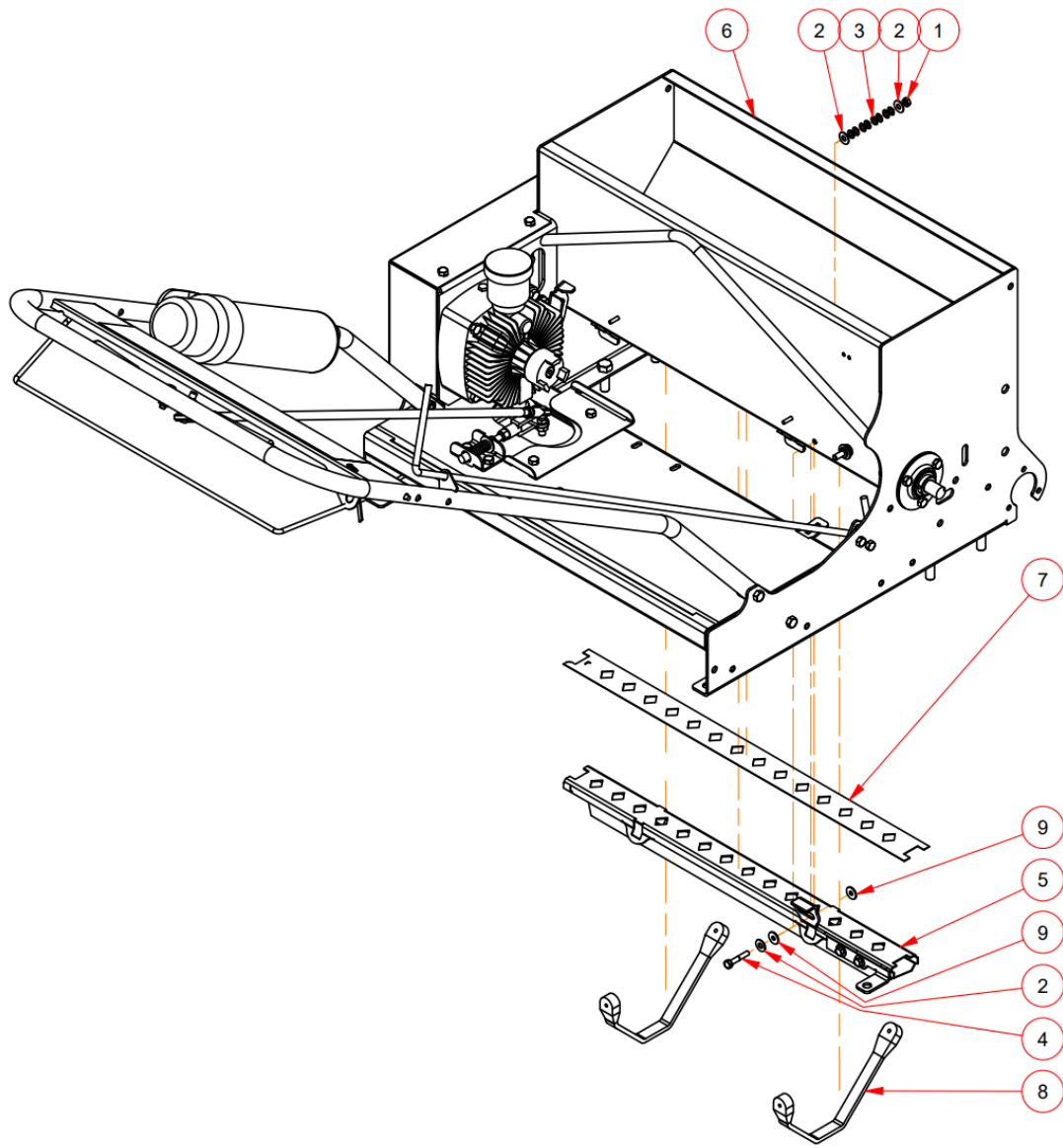

SEED RATE CONTROL ASSEMBLY PARTS

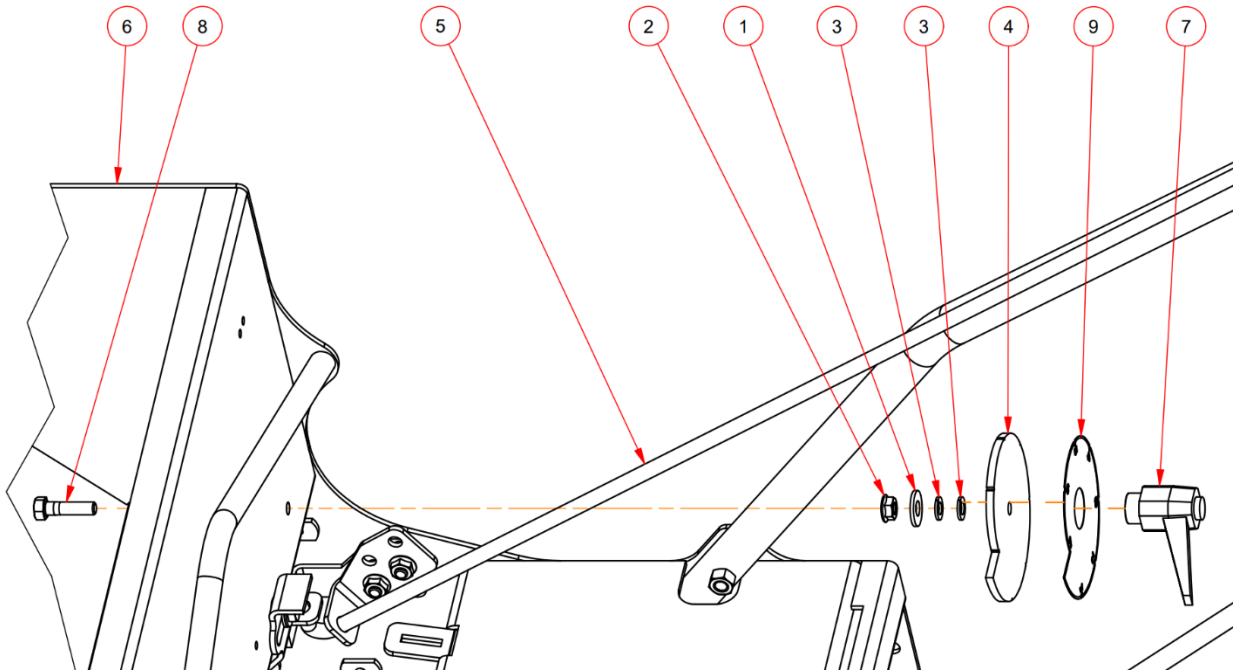

Parts List			
ITEM	QTY	PART NUMBER	DESCRIPTION
1	1	516F	Flat Washer
2	1	516FSLN	Flange Nut
3	2	516LO	BP Lock Washer
4	1	5099	Seed Rate Dial
5	1	5136	Seed Slide Lever
6	1	118648	Hopper Weldment AOS24SP
7	1	130636-AA	Indexed Clamping Lever
8	1	516114	Hex Bolt
9	1	RD119	Seed Rate Dial Decal

LID & LATCH ASSEMBLY PARTS

Parts List			
ITEM	QTY	PART NUMBER	DESCRIPTION
1	1	2-34 1901-R	Latch Female
2	2	38CLN	NC Lock Nut
3	2	38FL	BP Flat Washer
4	2	3834	Hex Bolt
5	1	102500	Lid AOS24SP
6	4	118053	Al Blind Rivet with Al Mandrel - 316
7	1	118648	Hopper Weldment AOS24SP
8	1	118697	Lid Hold Down Rubber Latch

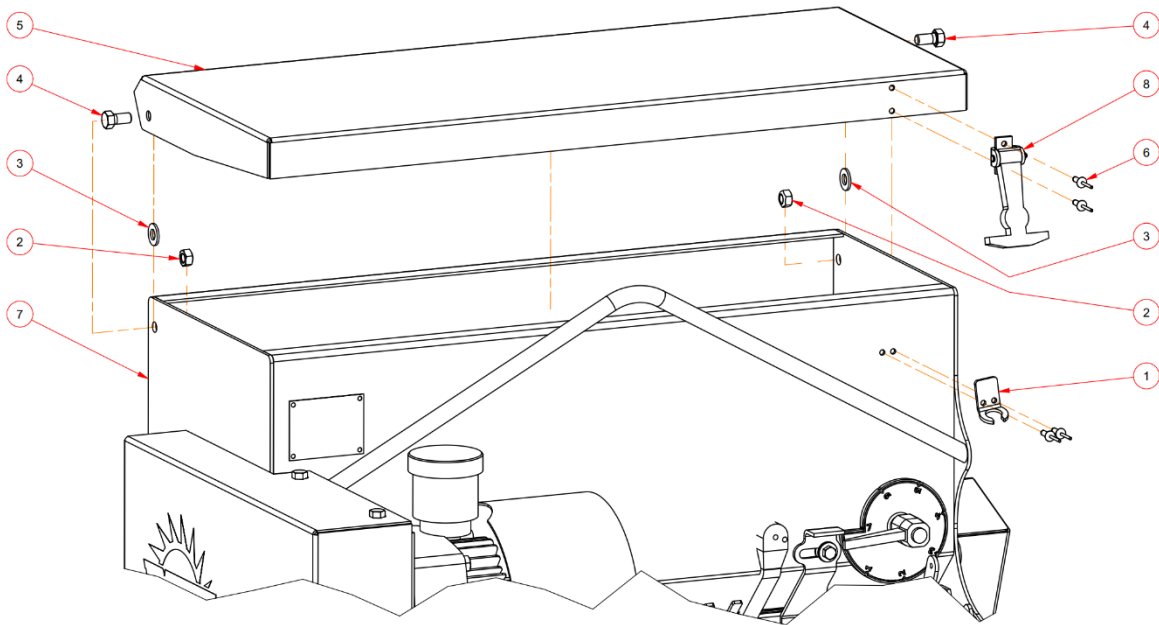

SPIKED ROLL TO REAR SPIKED ROLL DRIVE CONNECTION

Parts List			
ITEM	QTY	PART NUMBER	DESCRIPTION
1	4	12FSLN	Flange Nut
2	1	40B17X1	Roller Chain Sprocket - 40B17X1
3	1	40B18X1	Roller Chain Sprocket - 40B18X1
4	1	40RC	Roller Chain
5	1	5109	Rear Roll Drive Chain Shield
6	3	51634	Hex Bolt
7	1	118648	Hopper Weldment AOS24SP
8	1	501424	Spike Drive Roll Assembly AOS24SP
9	2	UCP205-100	Pillow Block Bearing

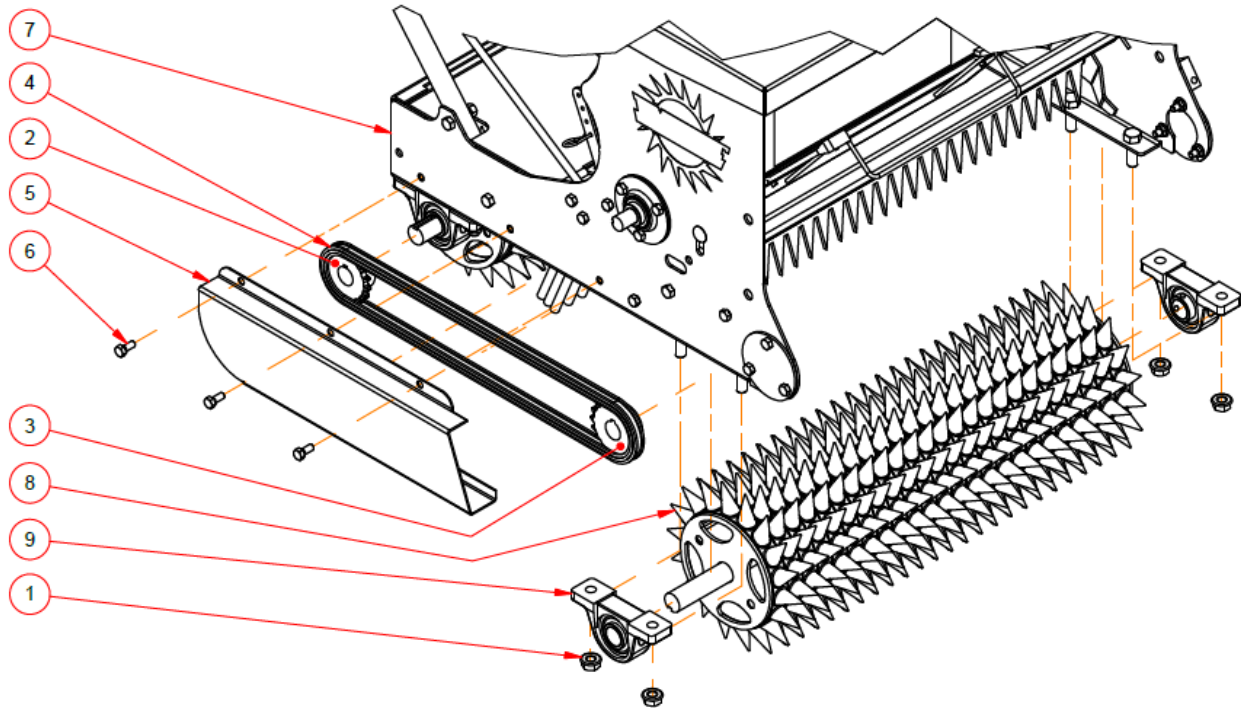

AGITATOR TO FRONT SPIKED ROLL DRIVE CONNECTION

Parts List			
ITEM	QTY	PART NUMBER	DESCRIPTION
1	1	40B12X34	Roller Chain Sprocket - 40B12X3/4
2	1	40B24X1	Roller Chain Sprocket - 40B24X1
3	1	40RC	Roller Chain
4	1	58FSLN	Flange Nut
5	1	583	Hex Bolt
6	1	5109	Rear Roll Drive Chain Shield
7	3	51634	Hex Bolt
8	1	100566	Tightener Cap
9	1	125695	AOS Disc Agitator 24
10	1	108092	Idler Bushing
11	1	108093	Front Roll Drive Chain Shield
12	1	118648	Hopper Weldment AOS24SP
13	1	501424	Spike Drive Roll Assembly AOS24SP
14	1	20401708	Tensioner Sprocket

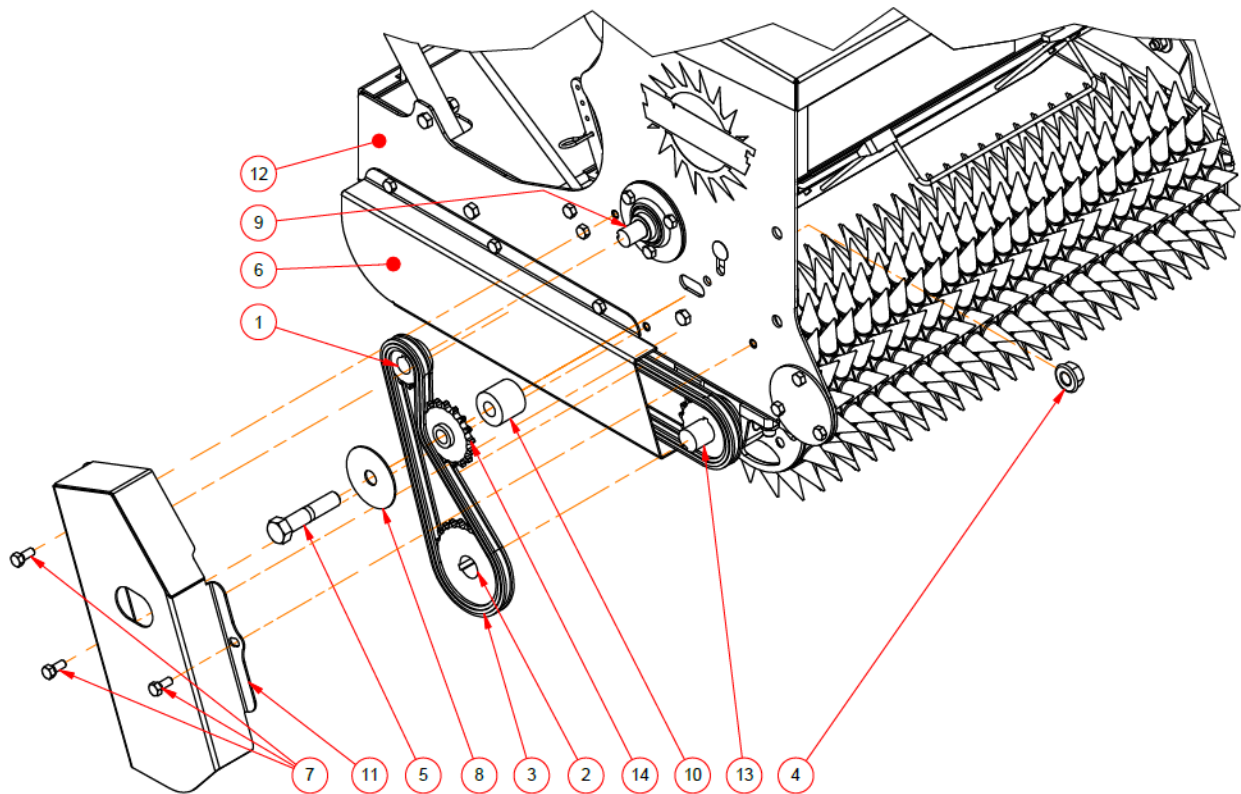

REAR SPIKED ROLL & SCRAPER ASSEMBLY

Parts List			
ITEM	QTY	PART NUMBER	DESCRIPTION
1	4	12FSLN	Flange Nut
2	2	5130	Bearing Bolt Plate Weldment
3	1	103059	Rear Spike Drive Roll
4	1	103073	Rear Spike Bracket Weldment
5	1	103074	Rear Peg Scraper
6	1	382	Hex Bolt
7	2	3834	Hex Bolt
8	2	383C	Carriage Bolt
9	2	38F	Flat Washer
10	5	38FSLN	Flange Nut
11	1	5125	Stop Bushing
12	2	5132	Peg Scraper Swing Bushing
13	2	58F	Flat Washer
14	2	TT343-02-LH	Torsion Spring
15	1	118648	Hopper Weldment AOS24SP
16	2	SCSD100	Shaft Collar Double Split 1
17	2	UCP205-100	Pillow Block Bearing

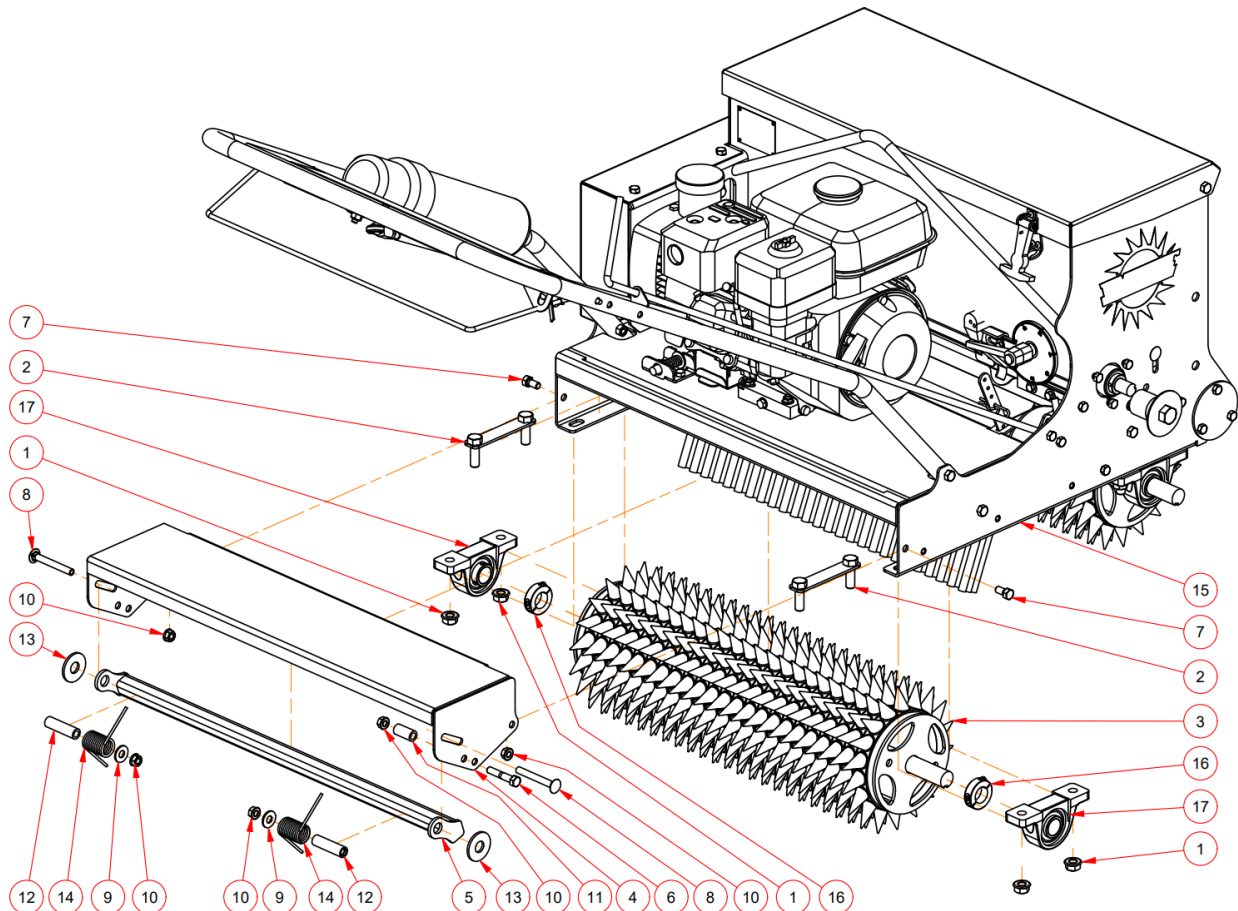

FRONT CONE SCRAPER & CALIBRATION TRAY ASSEMBLY

Parts List			
ITEM	QTY	PART NUMBER	DESCRIPTION
1	2	38F	Flat Washer
2	3	38FSLN	Flange Nut
3	2	58F	Flat Washer
4	1	382	Hex Bolt
5	2	383C	Carriage Bolt
6	1	5125	Stop Bushing
7	2	5132	Peg Scraper Swing Bushing
8	1	100564	Calibration Tray Assembly AOS24SP
9	1	118648	Hopper Weldment AOS24SP
10	1	501524	Front Peg Scraper Weldment AOS24SP
11	2	TT343-02-LH	Torsion Spring

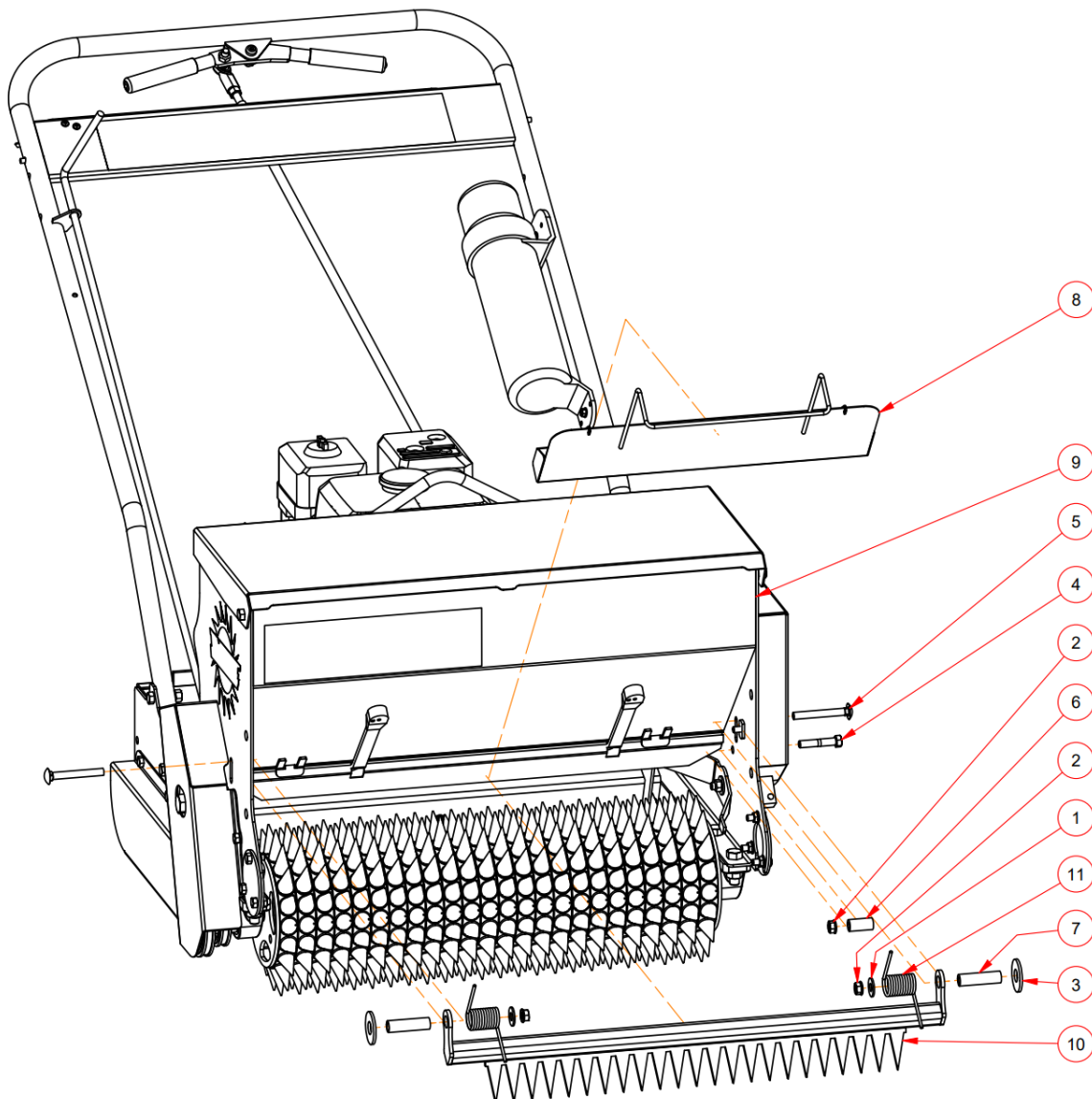

BRUSH ASSEMBLY

Parts List			
ITEM	QTY	PART NUMBER	DESCRIPTION
1	1	14CLN	NC Lock Nut
2	1	14FW	Flat Washer
3	2	38CLN	NC Lock Nut
4	2	38F	Flat Washer
5	2	381	Hex Bolt
6	6	516FSLN	Flange Nut
7	1	1434	Hex Bolt
8	1	5131	Broom Depth Gauge
9	6	51634	Hex Bolt
10	2	100584	Brg Hole Cover - 18, 24
11	1	102503	Brush Mount Weldment AOS24SP
12	1	102505	Brush AOS24SP
13	1	118648	Hopper Weldment AOS24SP
14	1	383503	COTTERS, HAIRPIN

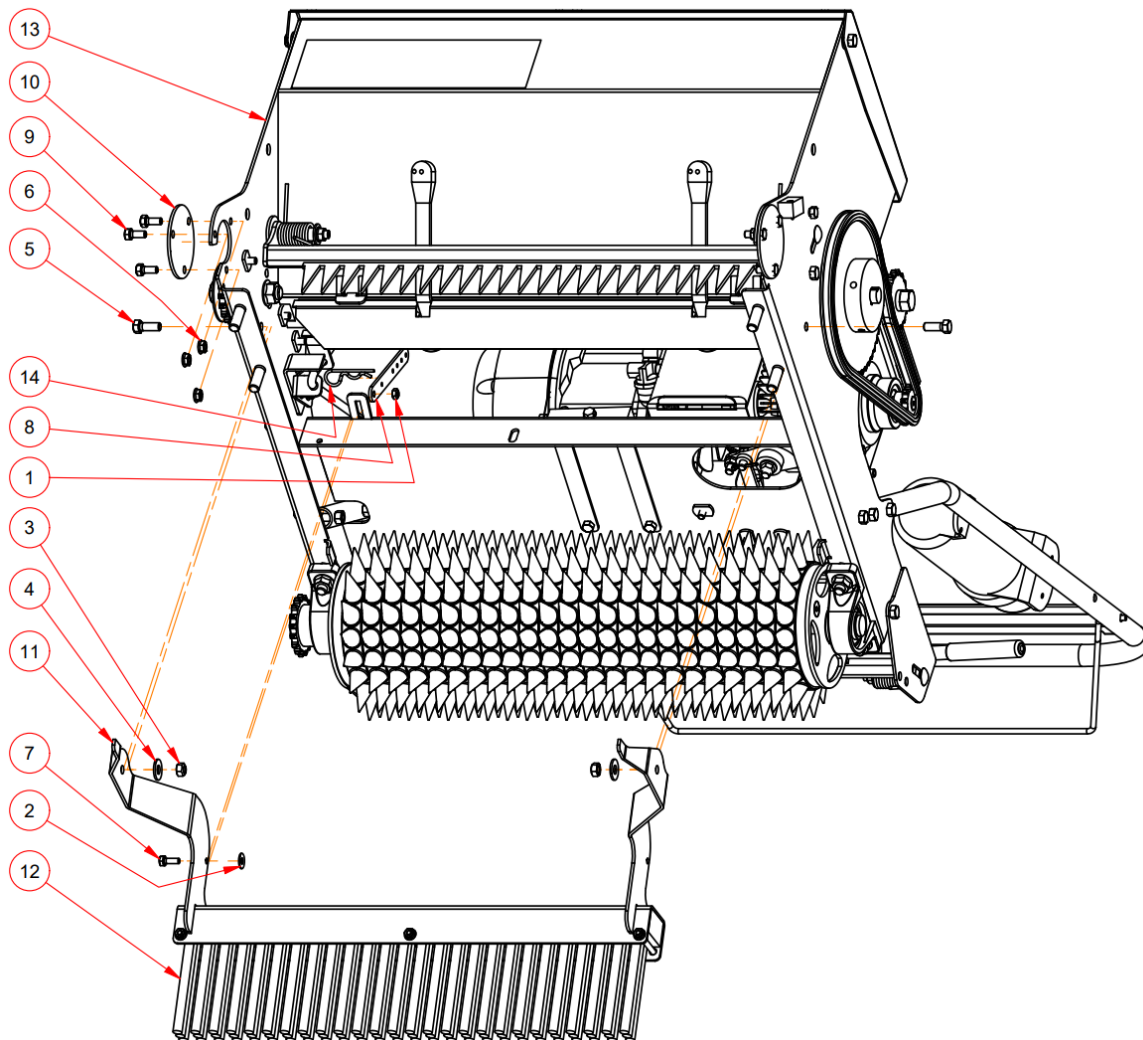

PARTS – DRIVE ROLL & BROOM

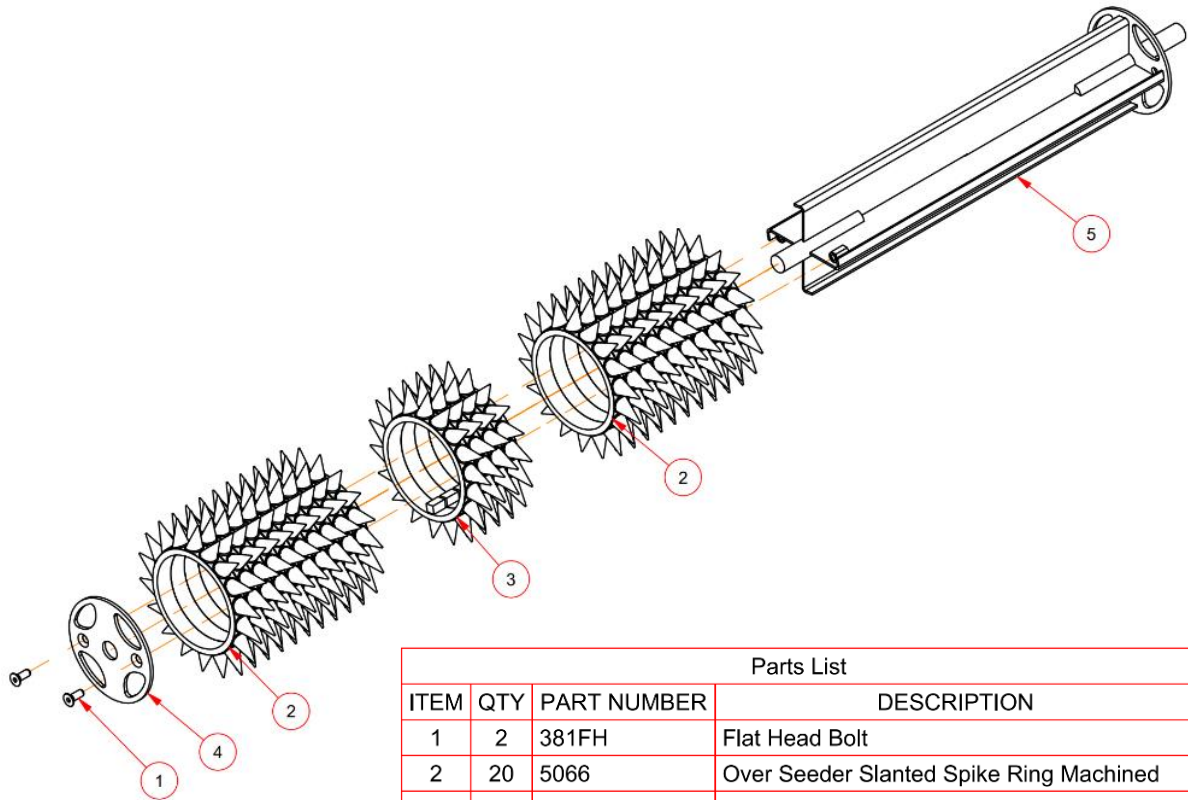

Parts List			
ITEM	QTY	PART NUMBER	DESCRIPTION
1	2	381FH	Flat Head Bolt
2	20	5066	Over Seeder Slanted Spike Ring Machined
3	4	5067	Over Seeder Drive Spike Slanted
4	1	115053	Spike Washer
5	1	505124	Drive Roll Weldment AOS24SP

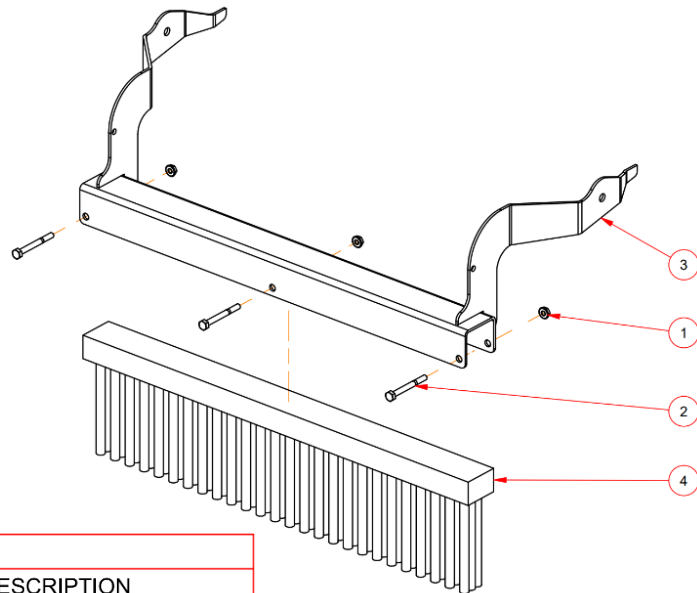

Parts List			
ITEM	QTY	PART NUMBER	DESCRIPTION
1	3	14FSLN	Flange Nut
2	3	14212	Hex Bolt
3	1	102503	Brush Mount Weldment AOS24SP
4	1	102505	Brush AOS24SP

PARTS – REAR SPIKE DRIVE ROLL

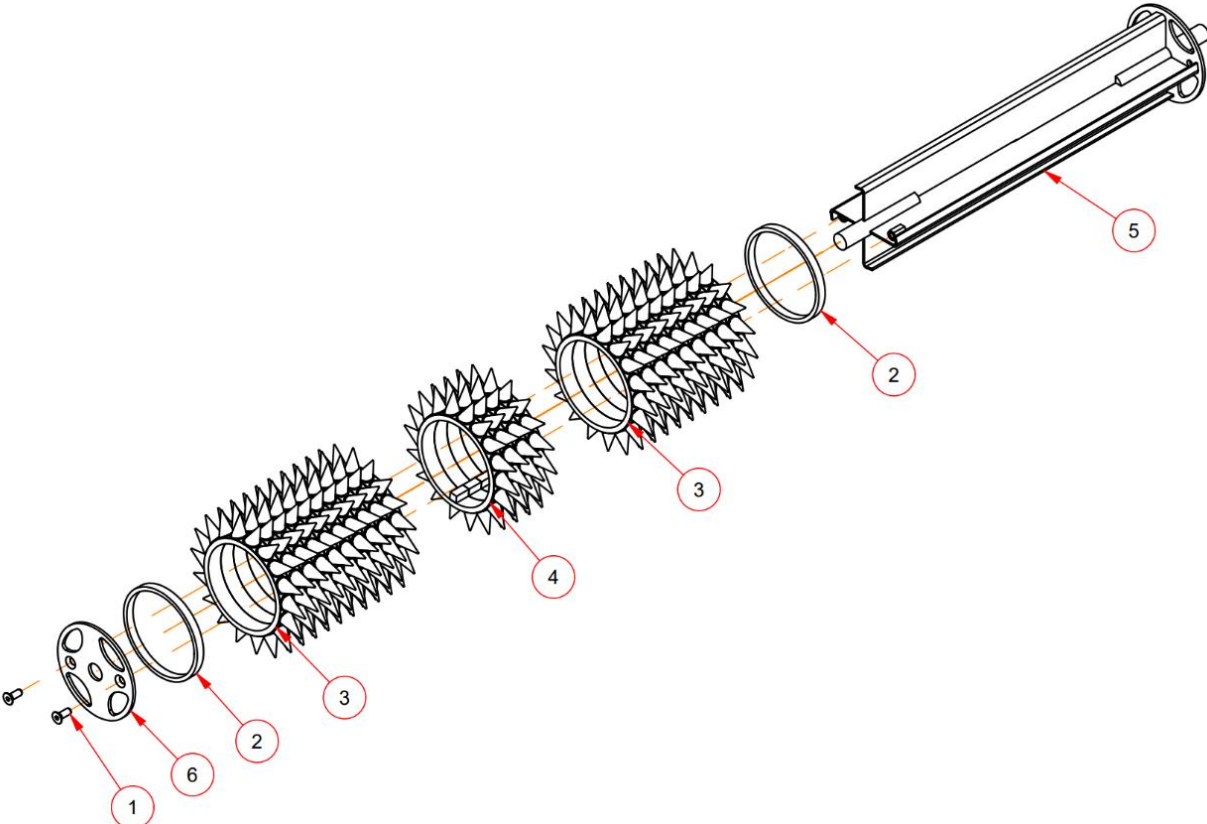

Parts List			
ITEM	QTY	PART NUMBER	DESCRIPTION
1	2	381FH	Flat Head Bolt
2	2	5051	Rear Spike Roll Spacer
3	19	5066	Over Seeder Slanted Spike Ring Machined
4	4	5067	Over Seeder Drive Spike Slanted
5	1	103060	Rear Spike Drive Roll 24
6	1	115053	Spike Washer

OPTIONAL 2" WIDE x 8" DIA GAUGE WHEEL KIT

Parts List				Parts List			
ITEM	QTY	PART NUMBER	DESCRIPTION	ITEM	QTY	PART NUMBER	DESCRIPTION
1	2	8SPNBB-3/4	Wheel	16	1	5122	Lift Bushing
2	2	12*3	Hex Bolt	17	1	5123	Wheel Lift Shaft
3	6	38CLN	NC Lock Nut	18	1	5124	Broom Lifter
4	4	38F	Flat Washer	19	2	5125	Stop Bushing
5	3	38N	Hex Nut	20	2	5127	Wheel Spacer
6	2	58F	Flat Washer	21	1	5129	Lift Linkage
7	3	316KS1	Keystock	22	6	51634	Hex Bolt
8	2	382	Hex Bolt	23	3	131093-AA	Set Screw - Cup Point 1/4-20 x 5/16 in
9	2	383	Hex Bolt	24	3	131094-AA	Set Screw - Flat Tip 1/4-20 x 1/4 in
10	3	516F	Flat Washer	25	4	131098-AA	Set Screw - Flat Tip M6x1 x 8mm
11	6	516FSLN	Flange Nut	26	1	FT10	382 full thread bolt 3/8-2
12	1	5118	Lift Linkage Lever	27	3	HX-3811SB	Hex Head Shoulder Bolt
13	1	5119	Lift Linkage B	28	4	PF204	brg flange
14	1	5120	Lift Handle	29	2	UC204012	Bearing Insert
15	2	5121	Wheel Mount				

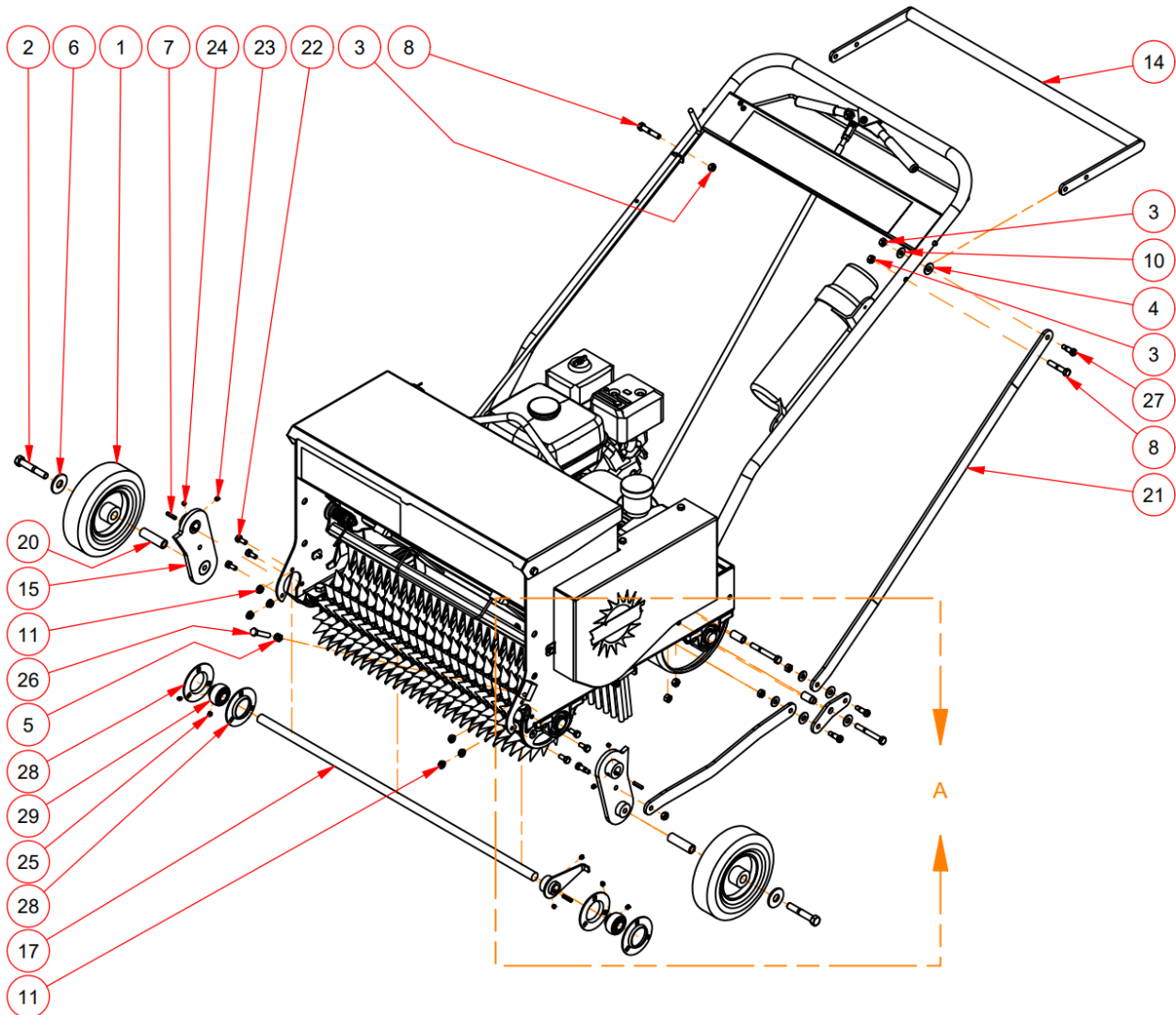

OPTIONAL 2" WIDE GAUGE WHEEL KIT – DETAIL A

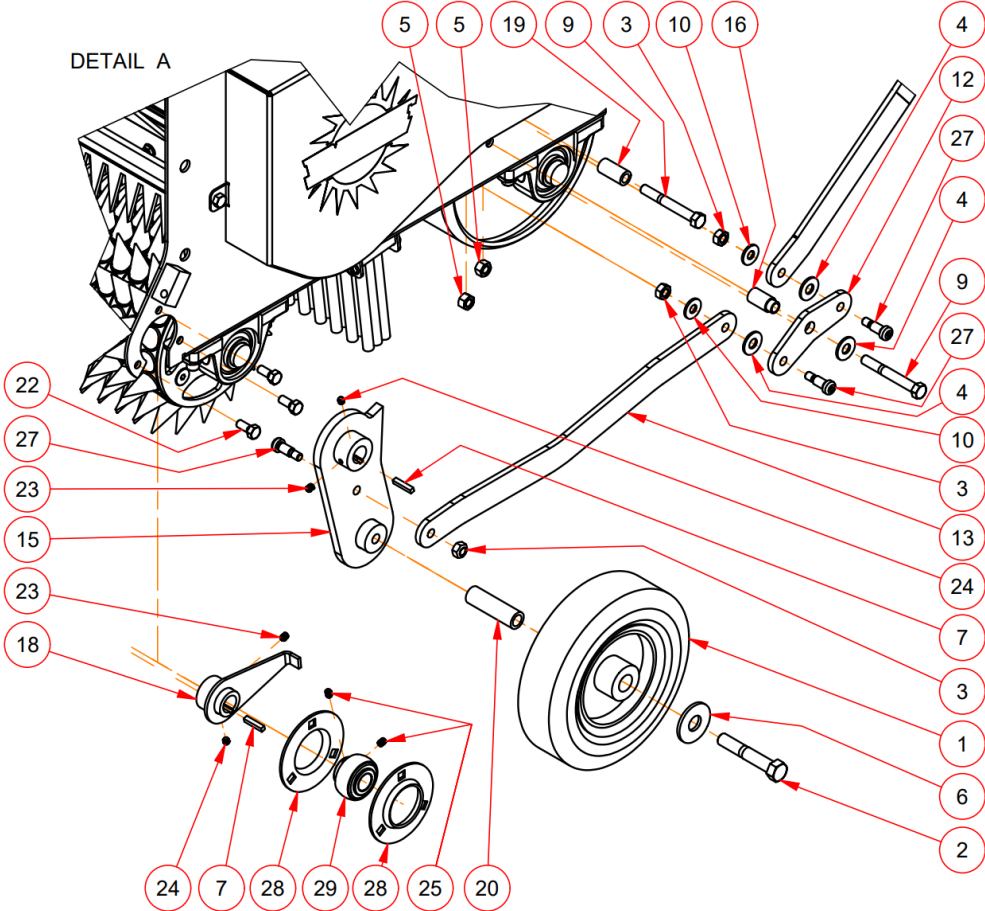

OPTIONAL 4" WIDE x 8" DIA GAUGE WHEEL KIT

The 4" Gauge Wheel linkage kit is the same as the one used for the optional 2" wide x 8" dia. gauge wheel kit. The only difference is that the wheels are wider. They are assembled as detailed below.

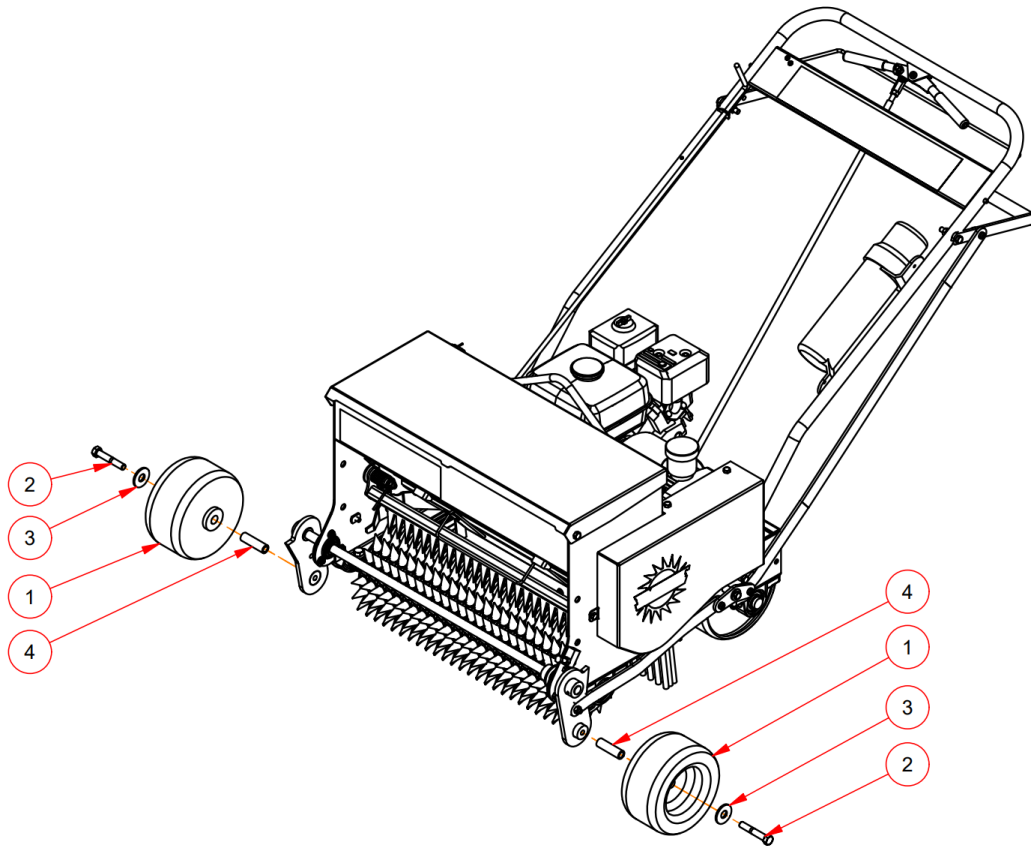

Parts List			
ITEM	QTY	PART NUMBER	DESCRIPTION
1	2	4X8GW	UHMW wheel
2	2	12*3	Hex Bolt
3	5	58F	Flat Washer
4	2	5127	Wheel Spacer

OPTIONAL WEIGHT BRACKET KIT

The Weight Bracket holds up to six 45 pound weights and is used for harder soil conditions to increase spike penetration.

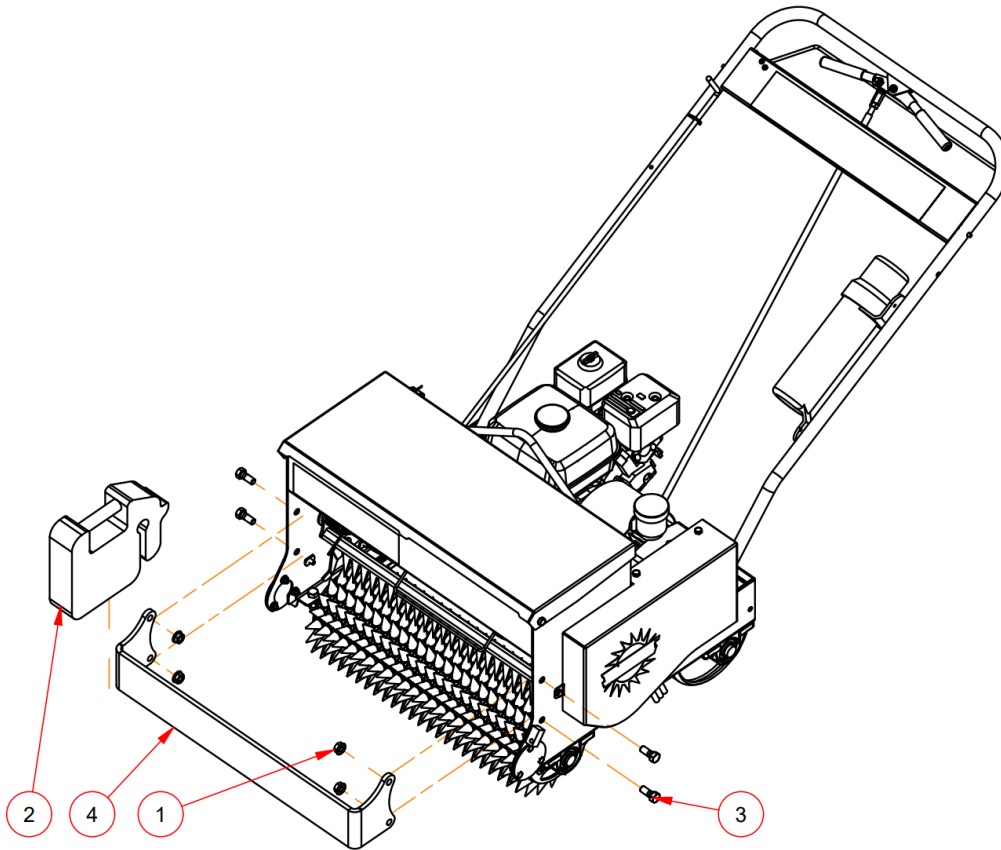

Parts List			
ITEM	QTY	PART NUMBER	DESCRIPTION
1	4	12FSLN	Flange Nut
2	6	45LBW	Weight
3	4	12114	Hex Bolt
4	1	S138	Weight Bracket

WARRANTY INFORMATION

All new REIST machinery is warranted to be free from defects in material or workmanship, which may cause failure under normal usage and service when used for the purpose intended for a period of 12 months. This warranty applies only to a new REIST product, there being no warranty of any nature in respect to new products that have been modified or altered, repaired, neglected, or used in any way, which, in the opinion of REIST adversely affects its performance.

In the event of failure of a part or parts, and upon inspection, REIST is satisfied that failure is due to defective material or workmanship within 12 calendar months from the date of delivery to an end user, such defective part or parts will be repaired or replaced by REIST Industries Inc. It is the responsibility of the buyer, at his expense, to transport the machine or equipment to the manufacturer service shop or to an authorized service depot or, alternatively, to reimburse REIST for any travel or transportation expense involved in fulfilling this warranty.

When requested by REIST, part or parts shall be returned for inspection, transportation prepaid, to a place designated by REIST. IN NO EVENT, SHALL THE BUYER BE ENTITLED TO RECOVER FOR INCIDENTAL OR CONSEQUENTIAL DAMAGES, INCLUDING, BUT NOT LIMITED TO, LOSS OF PRODUCT, INCONVENIENCE, RENTAL OR REPLACEMENT EQUIPMENT, LOSS OF PROFIT, OR OTHER COMMERCIAL LOSS.

This warranty becomes void and null if the equipment is modified, breaks down as the result of an accident, is not operated according to manufacturer's recommendations, damaged by negligence or if maintenance has not been carried out as specified.

THIS WARRANTY IS NOT TRANSFERABLE

Proof of Purchase – Retain for your records

Date of Purchase (yyyy/mm/dd)		Model	Serial #	
Dealer Purchased From		City	State or Province	Country
First Name		Last Name	Phone Number (include area code)	
Address			State or Province	Country
City	Postal Code	Return to: REIST Industries Inc. 100 Union St., Elmira, Ontario, Canada N3B 2Z2 (519) 669-1501		

Remove bottom section and return to REIST Industries within 30 days of purchase



Proof of Purchase

Date of Purchase (yyyy/mm/dd)		Model	Serial #	
Dealer Purchased From		City	State or Province	Country
First Name		Last Name	Phone Number (include area code)	
Address			State or Province	Country
City	Postal Code	Return to: REIST Industries Inc. 100 Union St., Elmira, Ontario, Canada N3B 2Z2 (519) 669-1501		

REIST Industries Inc.
100 Union Street
Elmira, Ontario, Canada
N3B 2Z2

